

# INSTALLATION INSTRUCTIONS



## TRAIL-SAFE™ SAMURAI INNER AXLE SEAL

300748-3-KIT 1986-1995 SUZUKI SAMURAI (ALL ENGINES)

### KIT CONTENTS





## RECOMMENDED TOOLS

Ratchet & Socket Set

Torque Wrench

Suzuki Special Service Tool #09900-06107 (Snap Ring Tool)

Suzuki Special Service Tool #09941-58010 (50mm Spindle Lock Nut Socket)

Suzuki Special Service Tool #09913-65210 (Tie Rod End Remover)

Floor Jack

Jack Stand

Flat Head Screwdriver

Pull Scale (For Bearing Preload)

Oil Seal Puller

Oil Seal Installation Tool

Wheel Bearing Grease

## CAUTION

1. Read all instructions completely and carefully before you begin. If anything is not clear, please call our tech support line at 1.877.4X4.TOYS or 559.252.4950 before proceeding.
2. Check to make sure the kit is complete and that no parts are missing (refer to the Kit Contents Section on the first page of these instructions). If anything is missing, please contact Trail-Gear at 1.877.4X4.TOYS or 559.252.4950.
3. Park vehicle on a clean, dry, flat, level surface and block the tires so the vehicle cannot roll in either direction.
4. This kit is for off-road use only. It is recommended that the installation steps below be performed by a competent mechanic. Buyers and users of this product hereby expressly assume all risks associated with the installation and use of this kit.
5. This installation is typical for most Suzuki Samurai vehicles. Some years or models may vary. If necessary, refer to the proper Factory Service Manual for the year and model of your Samurai.

# INSTALLATION INSTRUCTIONS



## STEP 1

Loosen the (5) lug nuts securing the driver's side wheel to the axle. Raise the front end with a floor jack and place a jack stand under the frame. Remove the (5) lug nuts and remove the wheel from the axle. Save the wheel & lug nuts for reinstallation.

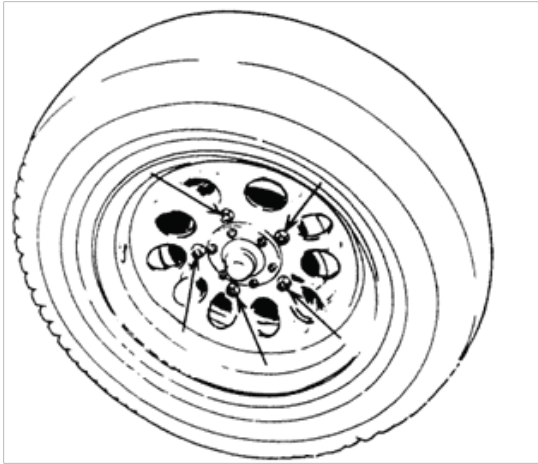

## STEP 2

Remove the brake calipers by loosening the carrier bolts. Hang the caliper from a wire hook as shown to avoid stretching the brake lines. Use care to make sure that the brake hose does not get twisted. **DO NOT** depress the brake pedal, or the piston will pop out of the caliper.

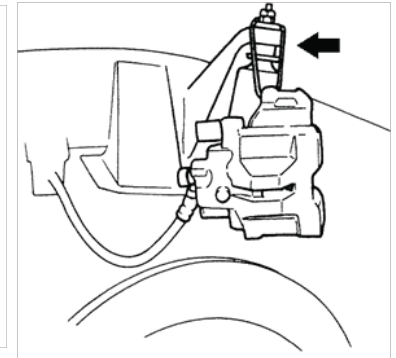
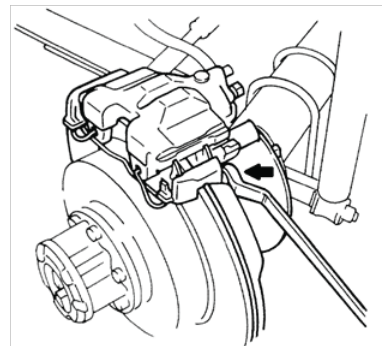

## STEP 3

Remove the rotor from the hub. If the rotor cannot be removed by hand, use (2) 8mm bolts to remove the rotor as shown.

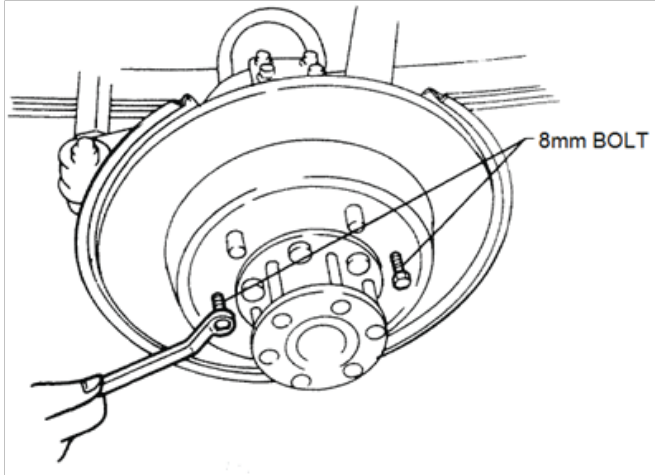

## STEP 4

For vehicles with Manual Locking Hubs, proceed to Step 5. If you do not have Manual Locking Hubs, skip to Step 8.

## STEP 5

Set the Locking Hub dial to the "Free" position. Loosen & remove the (6) screws securing the Manual Locking Hub Cover to the Locking Hub Body. Remove the Manual Locking Hub Cover. Save the Manual Locking Hub Cover and mounting hardware for reinstallation.

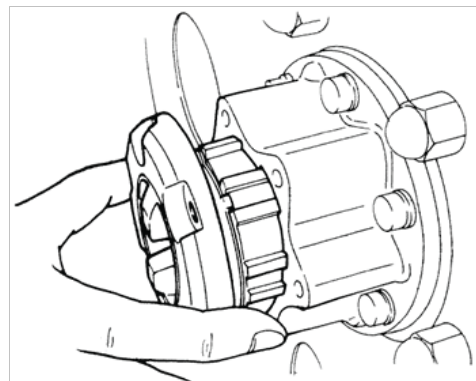
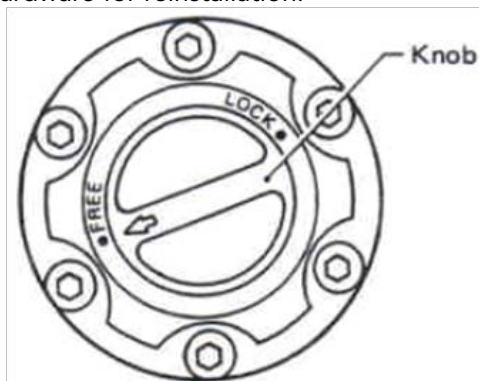

# INSTALLATION INSTRUCTIONS



## STEP 6

Remove the Circlip from the Hub Body using Suzuki Service Tool 09900-06107 or a commercially available snap ring remover. Save the Circlip for reinstallation.

## STEP 8

For vehicles not equipped with Manual Locking Hubs, remove the Front Axle Shaft Cap. Save the Shaft Cap for reinstallation.

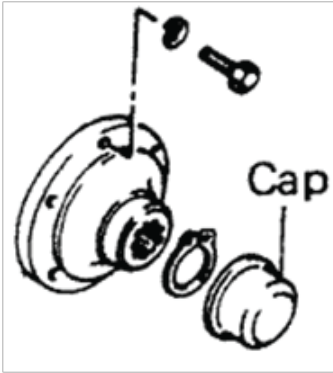

## STEP 7

Loosen and remove the (6) screws securing the Manual Locking Hub Body to the Hub. Save the Locking Hub Body and mounting hardware for reinstallation. Skip to Step 11.

## STEP 9

Using Suzuki Service Tool 09900-06107 or a commercially available snap ring remover, remove the Circlip that retains the Drive Flange to the Axle Shaft. Save the Circlip for reinstallation.

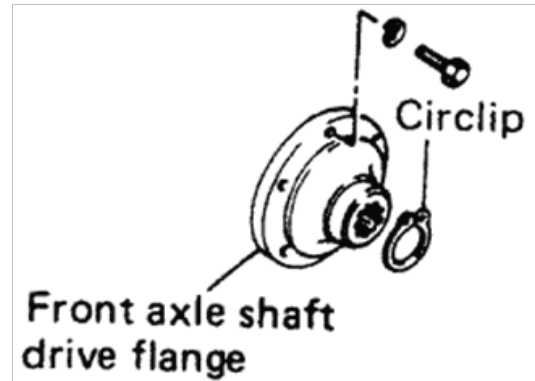

## STEP 10

Loosen and remove the Drive Flange mounting bolts and remove the Drive Flange. Save the mounting hardware and Drive Flange for reinstallation.

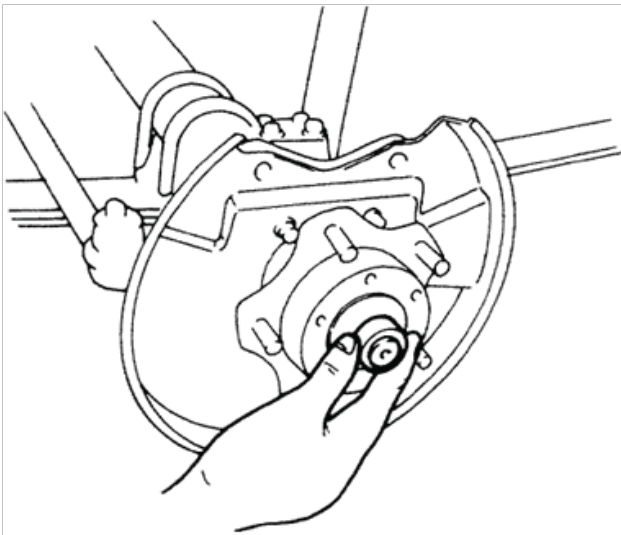

## STEP 11

Using a flat-head screwdriver, straighten the bent tabs of the Spindle Lock Washer. Loosen the Spindle Lock Nut using a 50mm socket or Suzuki Service Tool 09941-58010.

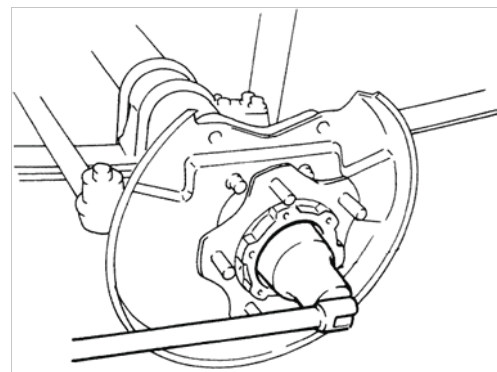
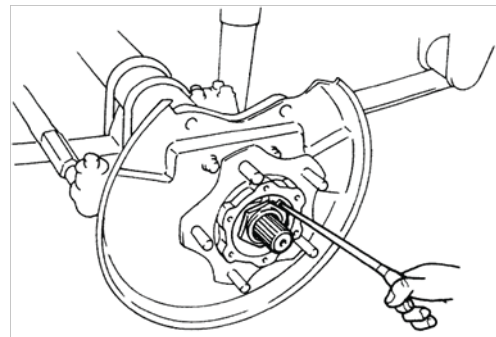

# INSTALLATION INSTRUCTIONS



## STEP 12

Remove the Spindle Lock Nut, Lock Washer, Spindle Nut, and Index Washer from the front spindle. Save both Nuts and both Washers for reinstallation.

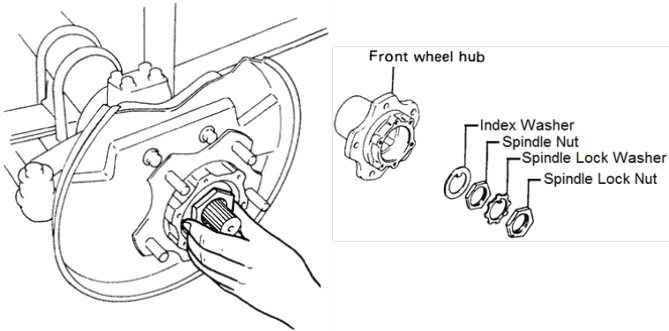

## STEP 13

Remove the Front Wheel Hub from the Spindle. Save the Hub for reinstallation.

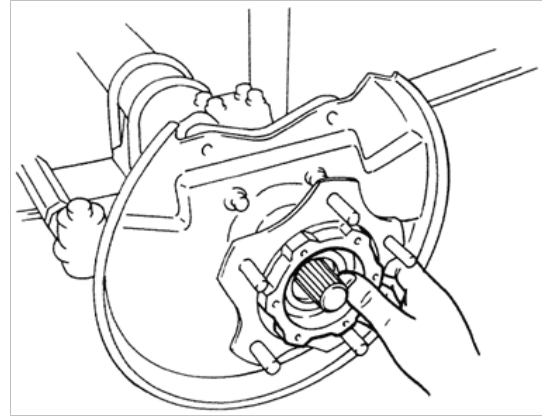

## STEP 14

Loosen, but do not remove, the (4) bolts on both the upper and lower bearing caps.

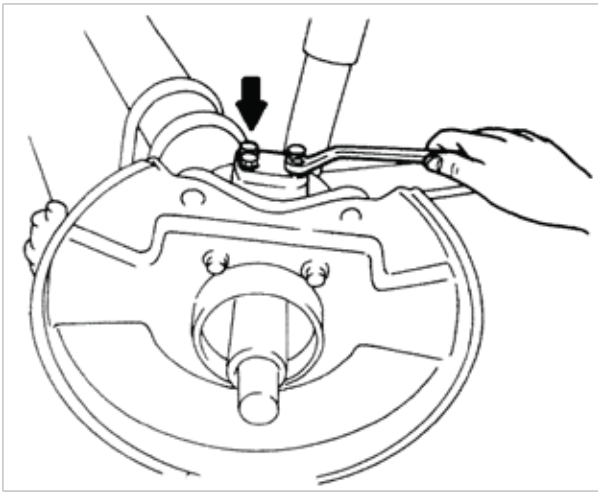

## STEP 15

Remove the (4) bolts securing the Rotor Dust Cover, Caliper Mount, and Spindle to the Knuckle. Remove the Rotor Dust Cover, Caliper Mount, and Spindle. Save the Rotor Dust Cover, Caliper Mount, Spindle, and hardware for reinstallation.

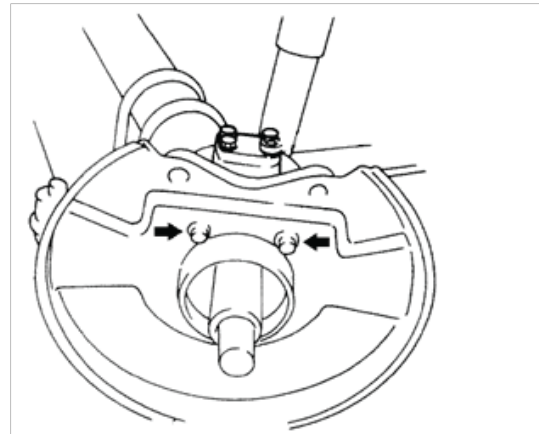

## STEP 16

Remove the Cotter Pin securing the Tie Rod Castle Nut. Remove the Castle Nut from the Tie Rod End. Disconnect the Tie Rod End from the Knuckle using a tie rod end remover or Suzuki Service Tool 09913-65210. Save the Cotter Pin and Castle Nut for reinstallation.

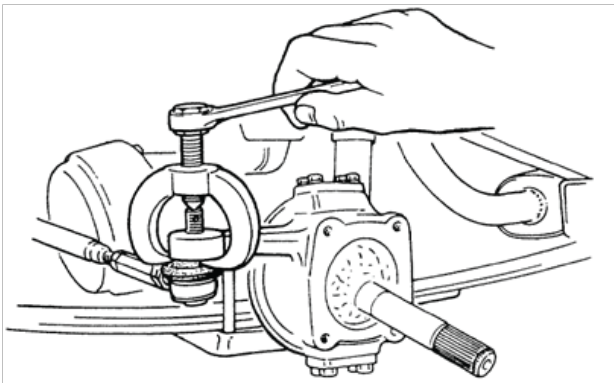

## STEP 17

Loosen and remove the Knuckle Seal bolts from the back of the Knuckle. Remove the Oil Seal Cover, Pad, Oil Seal, and Retainer from the Knuckle. Save all parts for reinstallation.

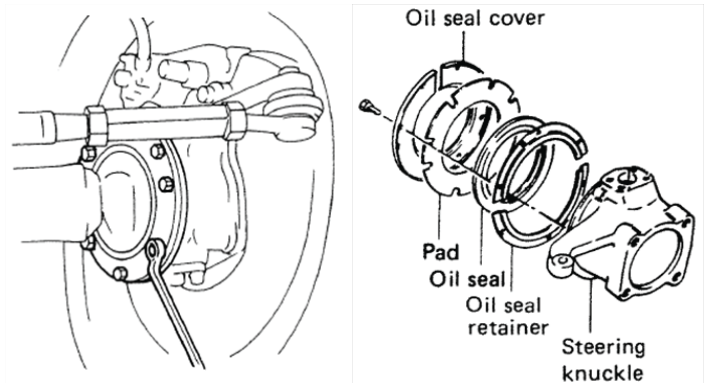

# INSTALLATION INSTRUCTIONS



## STEP 18

On each Bearing Cap, mark the Bearing Caps in such a manner that you can distinguish which one came from the top of the knuckle and vice versa. Make sure you keep the shims that were installed under each Bearing Cap with the corresponding Bearing Cap. Save all parts for reinstallation.

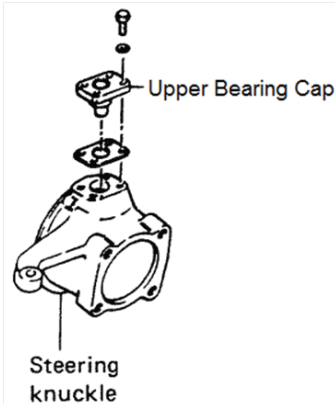

## STEP 19

Remove the Steering Knuckle from the Axle. Remove the Knuckle Bearings from the Knuckle. Mark the Knuckle Bearings in such a manner that you can distinguish which one came from the top of the Knuckle and vice versa. Save all parts for reinstallation.

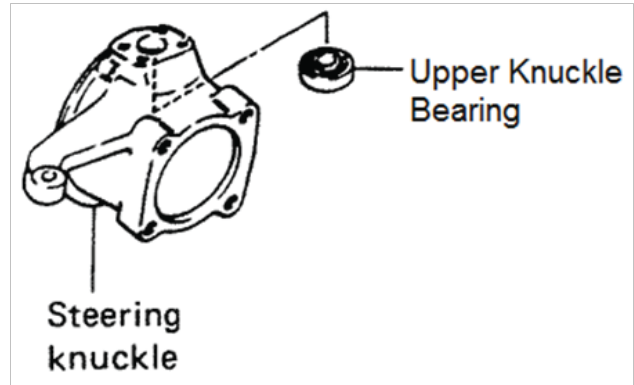

## STEP 20

Loosen and remove the differential Drain Plug. Drain the oil from the differential housing. Save the Drain Plug for reinstallation.

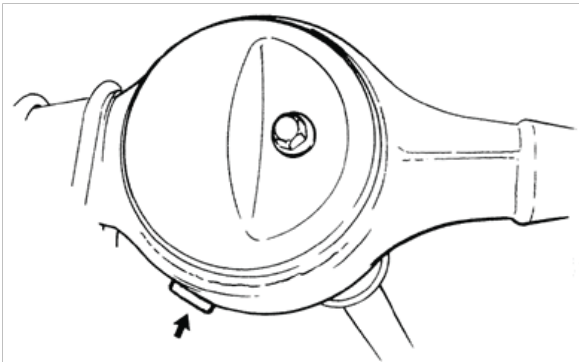

## STEP 21

Remove the Axle Shaft and Birfield Joint from the Axle Housing. Save the Axle Shaft & Birfield Joint for reinstallation.

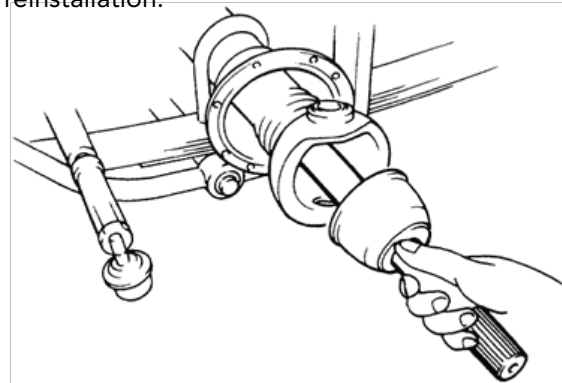

## STEP 22

Remove the stock inner axle seal using a Seal Puller. Discard the stock inner axle seal.

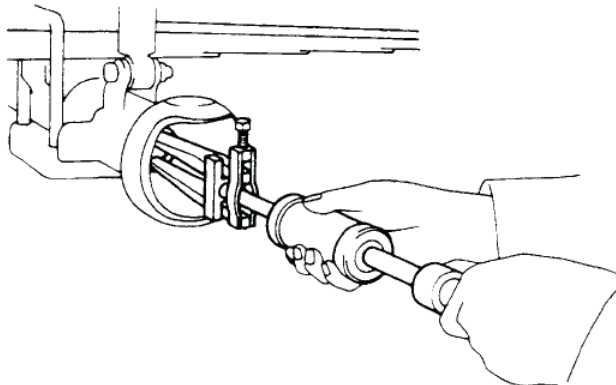

## STEP 23

Apply grease to both inner sealing lips of the Trail-Safe™ Inner Axle Seal.

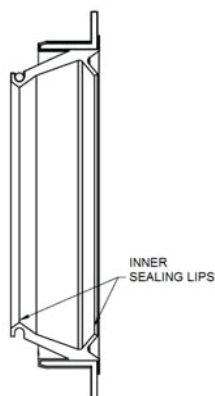

# INSTALLATION INSTRUCTIONS



## STEP 24

Install the Trail-Safe™ Inner Axle Seal into the Axle Housing using a Seal Installation tool.

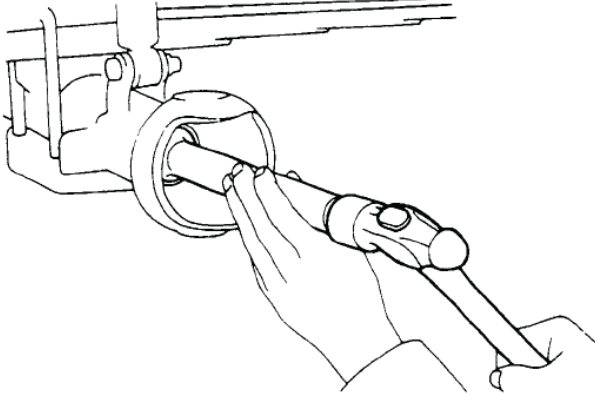

## STEP 25

Using the Axle Shaft & Birfield joint removed in Step 21, reinstall the Axle Shaft & Birfield joint into the Axle Housing.

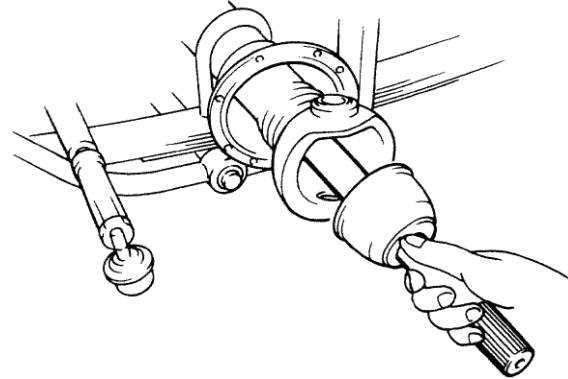

## STEP 26

Apply Suzuki Super Grease A 99000-25010 or equivalent to the Knuckle Bearing rollers. Install the Knuckle Bearings onto the Knuckle Ball, making sure to install the Knuckle Bearings in the same location they were removed from.

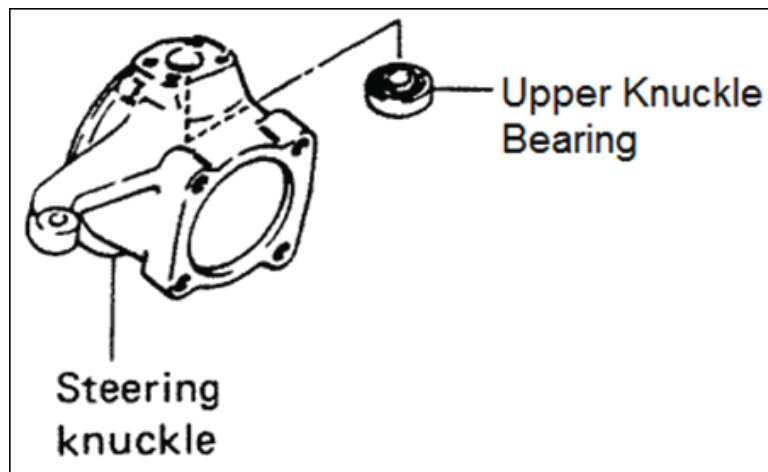

## STEP 27

Install the Knuckle back onto the Knuckle Ball. Install the Bearing Caps and shims back onto the Knuckle. Make sure to install the Bearing Caps and shims to the same location that they were removed from. Apply Suzuki Sealing Compound 366E 99000-31090 or equivalent to the underside of the Bearing Caps before installing them onto the Knuckle. Apply Suzuki Thread Lock Compound 1342 99000-32050 or equivalent to the Knuckle Cap Bolt and install them into the Knuckle. Torque each Knuckle Cap Bolt to 14.5-21.5 ft-lbs (20-30 N-m) or to the torque specified in the Suzuki Samurai Factory Service Manual.

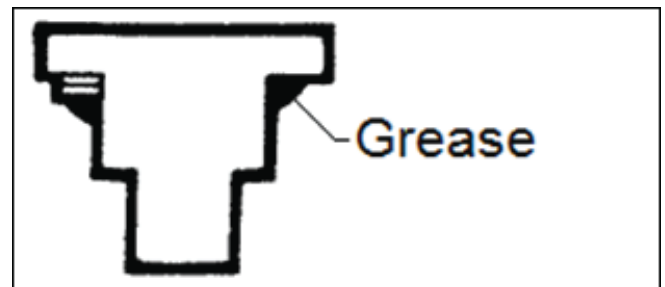
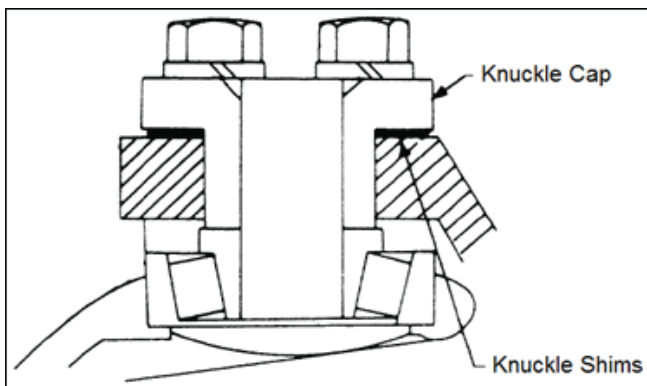

# INSTALLATION INSTRUCTIONS



## STEP 28

Reinstall the Oil Seal Retainer, Oil Seal, Pad, & Oil Seal Cover. Apply Suzuki Super Grease A 99000-25010 or equivalent to the lip of the Oil Seal as shown below. Apply Suzuki Sealing Compound 366E 99000-31090 or equivalent to the Oil Seal Retainer as shown below. Also, apply the same Sealing Compound between the two halves of the Oil Seal Retainer. Torque the Oil Seal Cover bolts to 6.0-8.5 ft-lbs (8-12 N-m) or to the torque specified in the Suzuki Samurai Factory Service Manual.

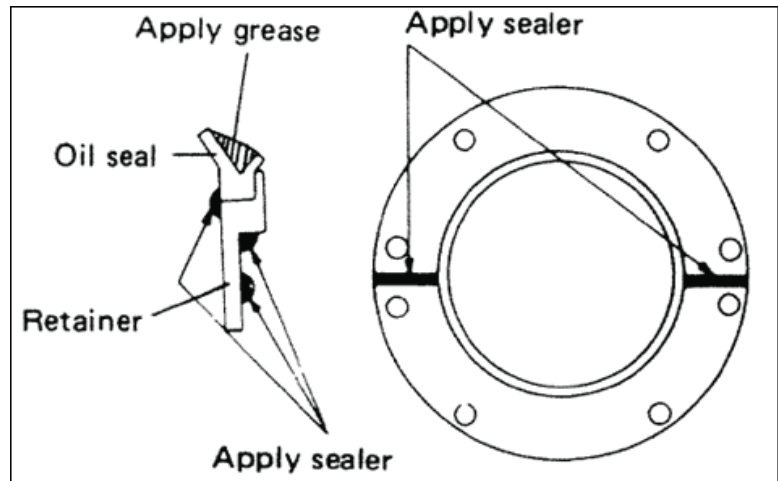
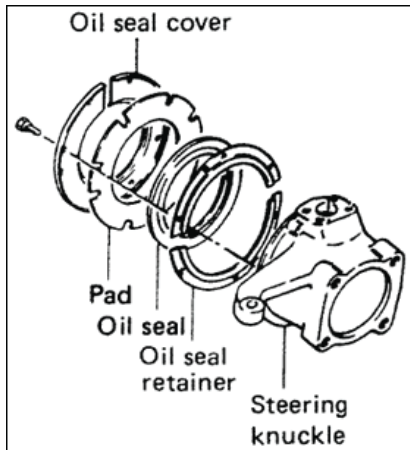

## STEP 29

Reconnect the Tie Rod End to the Steering Knuckle. Secure with the Castle Nut. Torque the Castle Nut to the torque specified in the Suzuki Samurai Factory Service Manual. Reinstall the Cotter Pin to secure the Castle Nut.

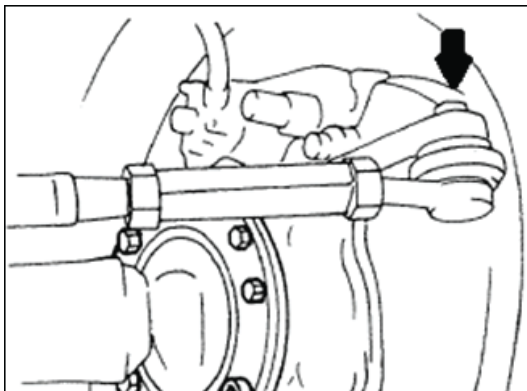

## STEP 30

Apply Suzuki Super Grease A 99000-25010 or equivalent to the inside of the Spindle Bushing. Apply Suzuki Sealing Compound 366E 99000-31090 or equivalent to the mating surfaces of the Rotor Dust Cover and Caliper Mount. Reinstall the Rotor Dust Cover, Caliper Mount, and Spindle to the Knuckle. Torque the mounting

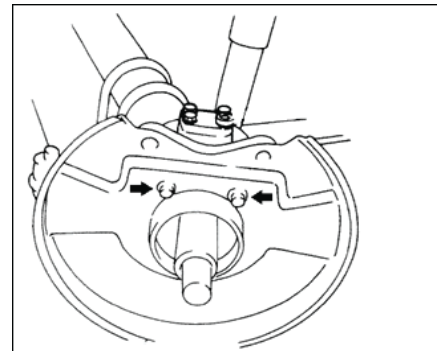

## STEP 31

Reinstall the Front Wheel Hub onto the Spindle.

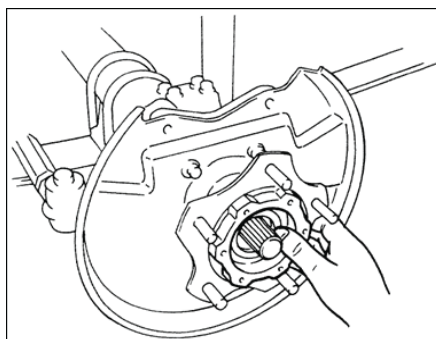

## STEP 32

Reinstall the Index Washer and Spindle Nut and torque to 87.5 ft-lbs (80 N-m). Loosen the nut, and then torque the Spindle Nut to 7.5-10.5 ft-lbs (10-15 N-m) or to the torque specified in the Suzuki Samurai Factory Service Manual.

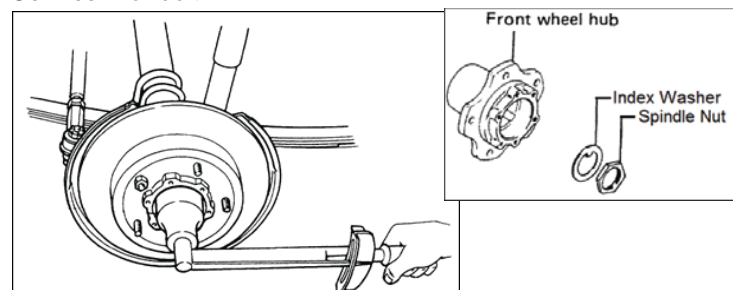



# INSTALLATION INSTRUCTIONS



## STEP 33

Reinstall the Spindle Lock Washer and Lock Nut back onto the Spindle. Torque the Lock Nut to 43.5-65 ft-lbs (60-90 N-m) or to the torque specified in the Suzuki Samurai Factory Service Manual. Bend one tab of the Lock Washer towards the Spindle Nut and bend another tab towards the Lock Nut.

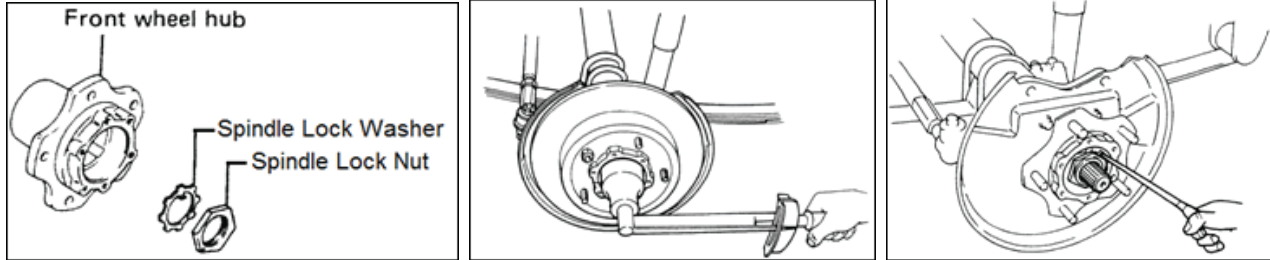

## STEP 34

Using a Pull Scale and the setup illustrated below, check the Wheel Bearing Preload. The Preload should be 2.2-6.6 lbs (1-3 kg) or in the range specified in the Suzuki Samurai Factory Service Manual. If it is not within the specified range, repeat steps 32 thru 34 until the Preload is within the specified range.

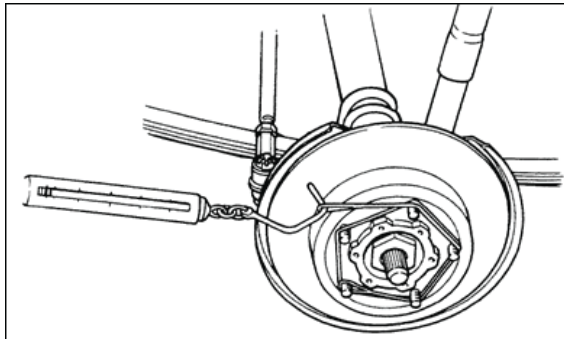

## STEP 35

On Vehicles with Drive Flanges, reinstall the Drive Flange back onto the Hub using the hardware removed in Step 10. Torque the bolts to 14.5-21.5 ft-lbs (20-30 N-m) or to the torque specified in the Suzuki Samurai Factory Service Manual.

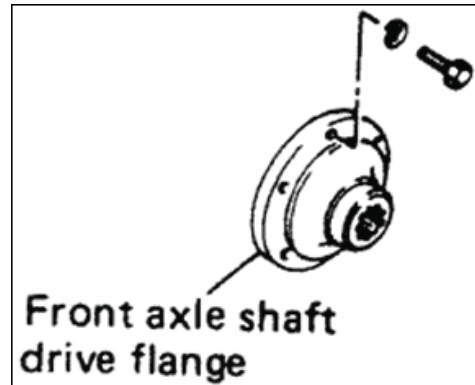

## STEP 36

On Vehicles with Drive Flanges, reinstall the Circlip back onto the Axle Shaft using Suzuki Service Tool 09900-06107 or a commercially available snap ring remover. Install the Front Axle Shaft Cap back onto the Drive Flange.

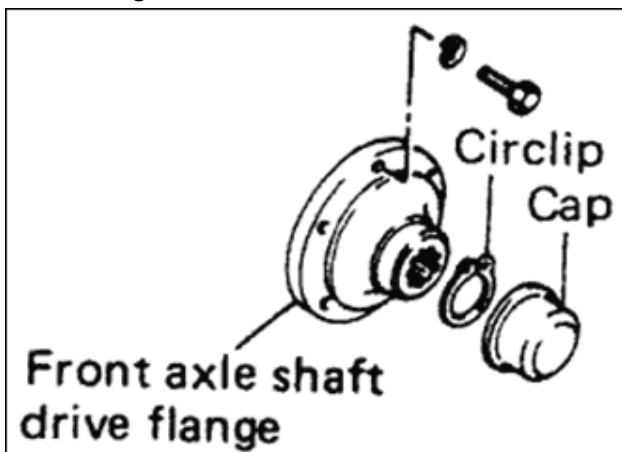

## STEP 37

On Vehicles with Manual Locking Hubs, apply a thin layer of Suzuki Sealing Compound 366E 99000-31090 or equivalent to the face of the hub.

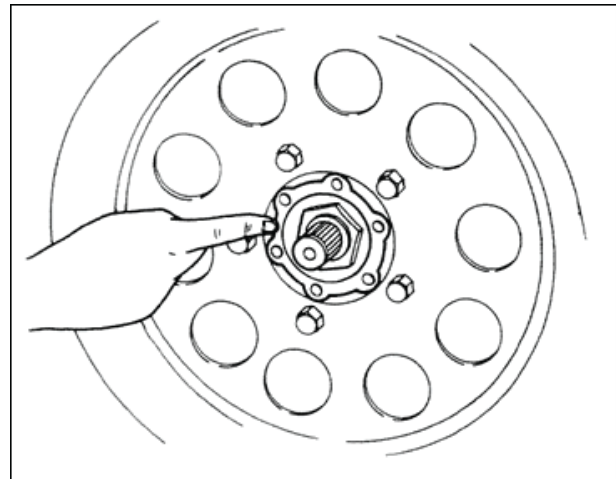

# INSTALLATION INSTRUCTIONS



## STEP 38

On Vehicles with Manual Locking Hubs, reinstall the Hub Gasket and Locking Hub Body back onto the Hub. Reinstall the Cone Washers and torque the mounting bolts to 14.5-21.5 ft-lbs (20-30 N-m) or to the torque specified in the Suzuki Samurai Factory Service Manual.

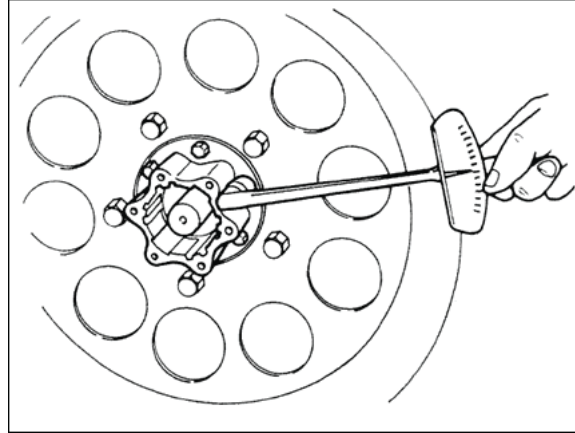
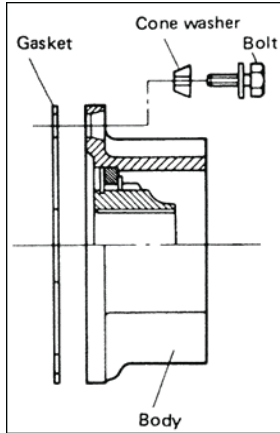

## STEP 39

On Vehicles with Manual Locking Hubs, pull the Axle Shaft out and install the Snap Ring into the groove on the Axle Shaft.

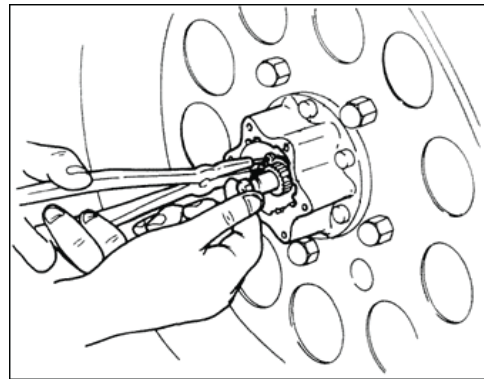

## STEP 40

On Vehicles with Manual Locking Hubs, install the Locking Hub Body Gasket onto the Locking Hub Body. Install the Cover/Clutch Assembly onto the Locking Hub Body. Make sure to align the Follower Stopper with the corresponding groove in the Locking Hub Body.

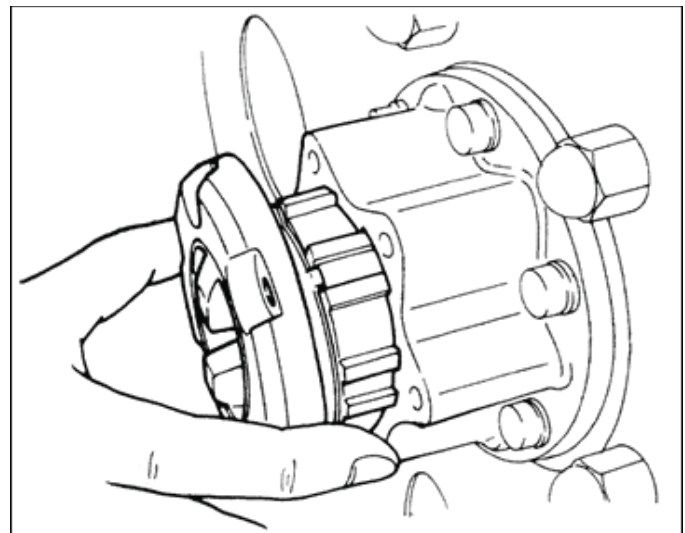
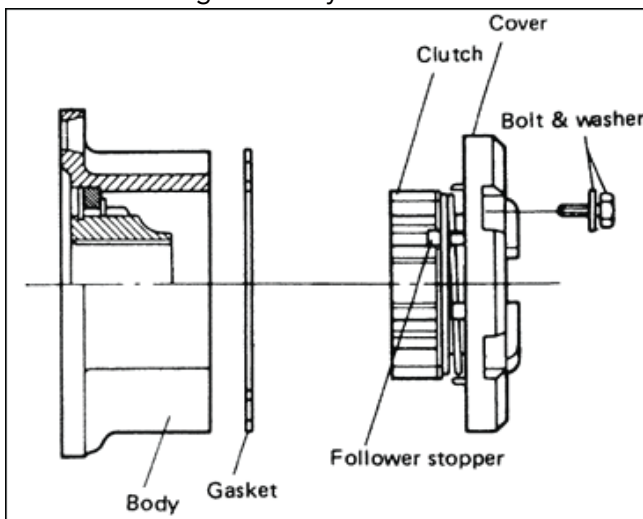

# INSTALLATION INSTRUCTIONS



## STEP 41

On Vehicles with Manual Locking Hubs, reinstall the Cover mounting bolts and washers. Torque the mounting bolts to 6-8.5 ft-lbs (8-12 N-m) or to the torque specified in the Suzuki Samurai Factory Service Manual.

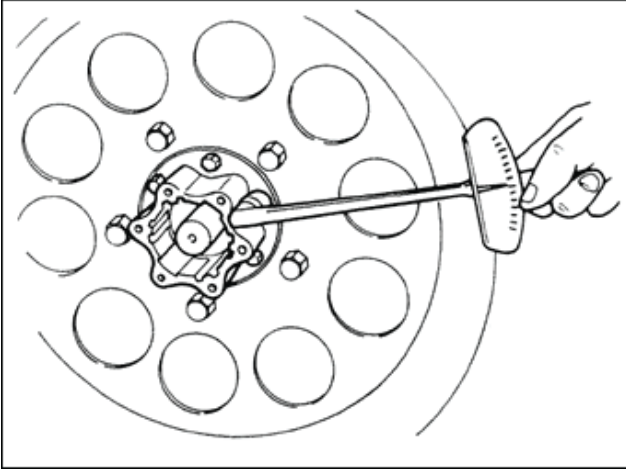

## STEP 42

Reinstall the wheel and Lug Nut. Torque the Lug Nuts to torque specified in the Suzuki Samurai Owner's Manual.

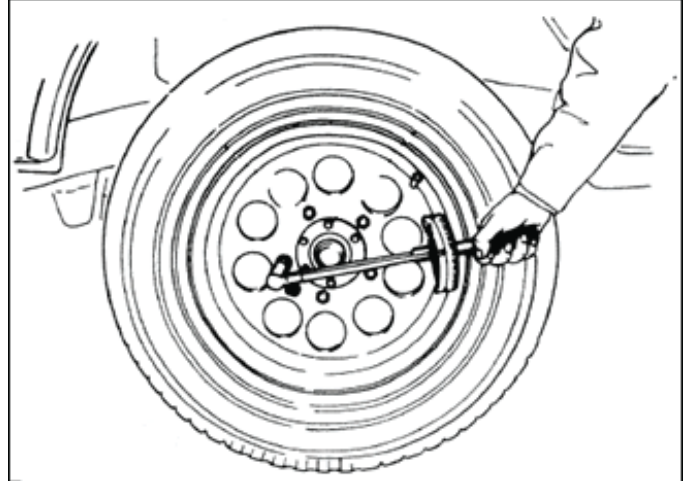

## STEP 43

Lower the vehicle. Repeat Steps 1-43 for the other side of the vehicle.

## STEP 44

Replace the Differential Drain Plug and torque to 13.5-18 ft-lbs (18-25 N-m) or to the torque specified in the Suzuki Samurai Factory Service Manual. Remove the Fill Plug and refill the differential with gear oil. Replace the Fill Plug and torque to 25.5-36 ft-lbs (35-50 N-m) or to the torque specified in the Suzuki Samurai Factory Service Manual.

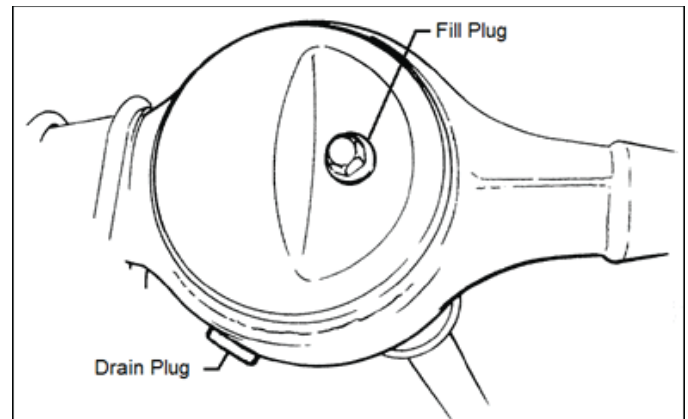

## STEP 45

Take the vehicle for a short test drive. After the test drive, check the torque on the Locking Hub hardware and tighten as necessary.

# INSTALLATION INSTRUCTIONS



## REPLACEMENT PARTS

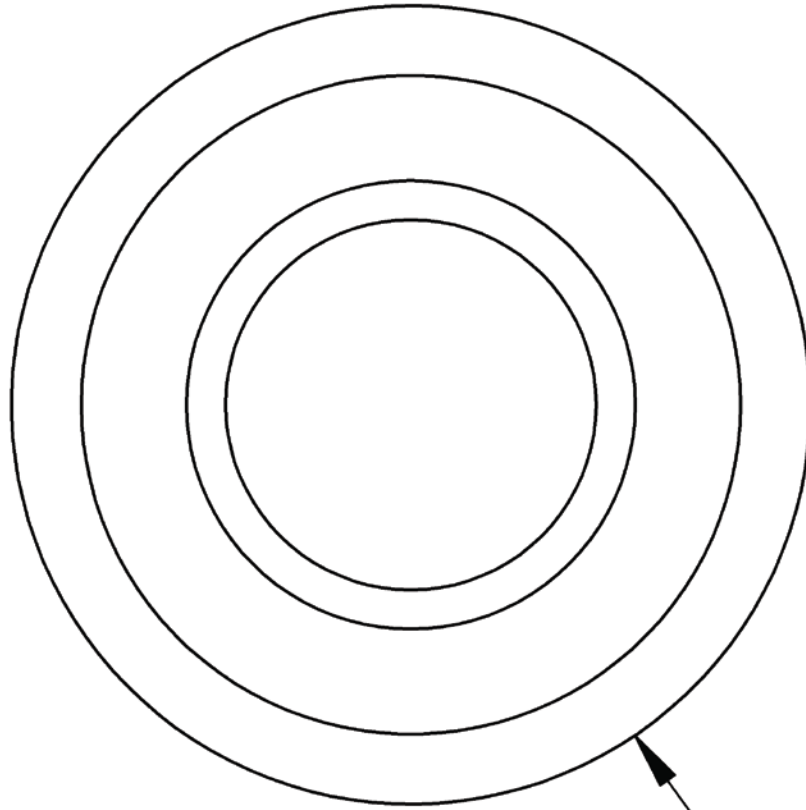

300742-3